

TORNADO

By Duraquip

3 COMPARTMENT SHORT SPECIFICATIONS

GA DRAWING / HOPPER SPLITS

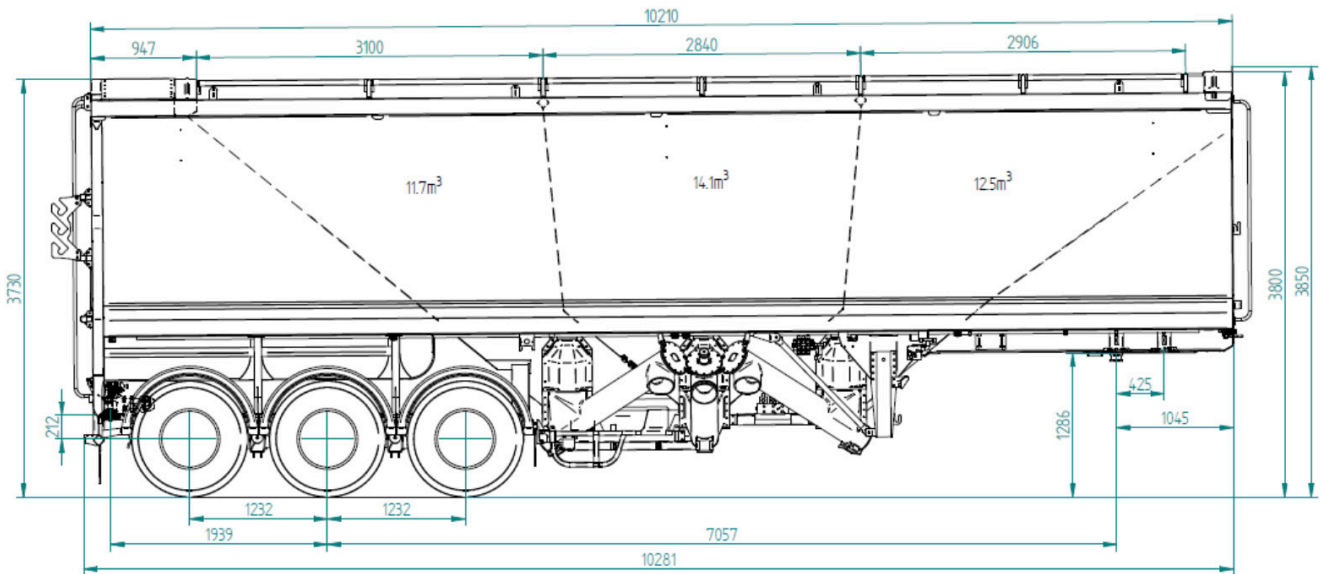

HOPPER CAPACITIES

TOTAL	43.4m ³	WHEAT	BARLEY	FERTILISER	UREA
HOPPER 1	12.5m ³	10.0T	8.75T	12.5T	8.75T
HOPPER 2	14.1m ³	11.28T	9.87T	14.1T	9.87T
HOPPER 3	12.1m ³	9.68T	8.47T	12.1T	8.47T
REAR	4.7m ³	3.6T	3.29T	4.7T	3.29T

TARE WEIGHT 8.9T

SUB-FRAME COLOURS



Call our knowledgeable sales team today to discuss the TORNADO and which model will best suit your operations!



1800 27 1800 | sales@duraquip.com.au